

Harnessing Carleton's Forgotten Data: Energy Analytics for Improved Campus Sustainability

Hannah Barnstone, Ethan Cassel-Mace, Alex Davis,
Eva Grench, Miaoye Que, and Chris Tordi

What is Energy Analytics?

- ▷ Data-driven tools to help institutions understand and manage their energy use
- ▷ Active area of research and development

Google

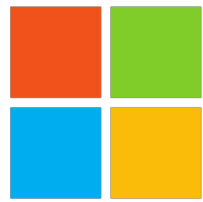

Microsoft

Why Energy Analytics at Carleton?



Martha Larson

Director of Campus Energy and Sustainability

Why Energy Analytics at Carleton?

CARBON
FREE
BY
2050

- ▷ By 2030: “Carleton will need to implement other aggressive carbon reduction strategies”
- ▷ Beyond 2030: “Carleton will need to implement yet to-be-determined future technologies”

Why Energy Analytics at Carleton?



- ▷ Carleton spends over \$3,000,000 on energy per year

Current System

Points!



EV.RM102.RT = 68°

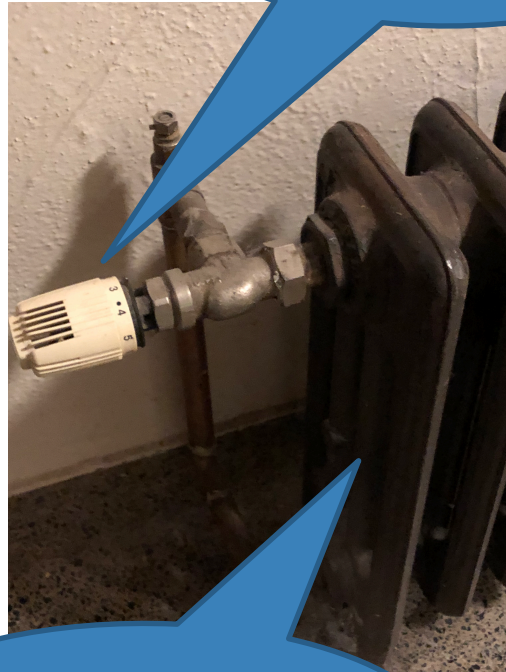

SHH.LF1.STPT = 68°

SHH.LF1.VALV = 75%



COA1SS = 35

COA1ST = 12

Current System

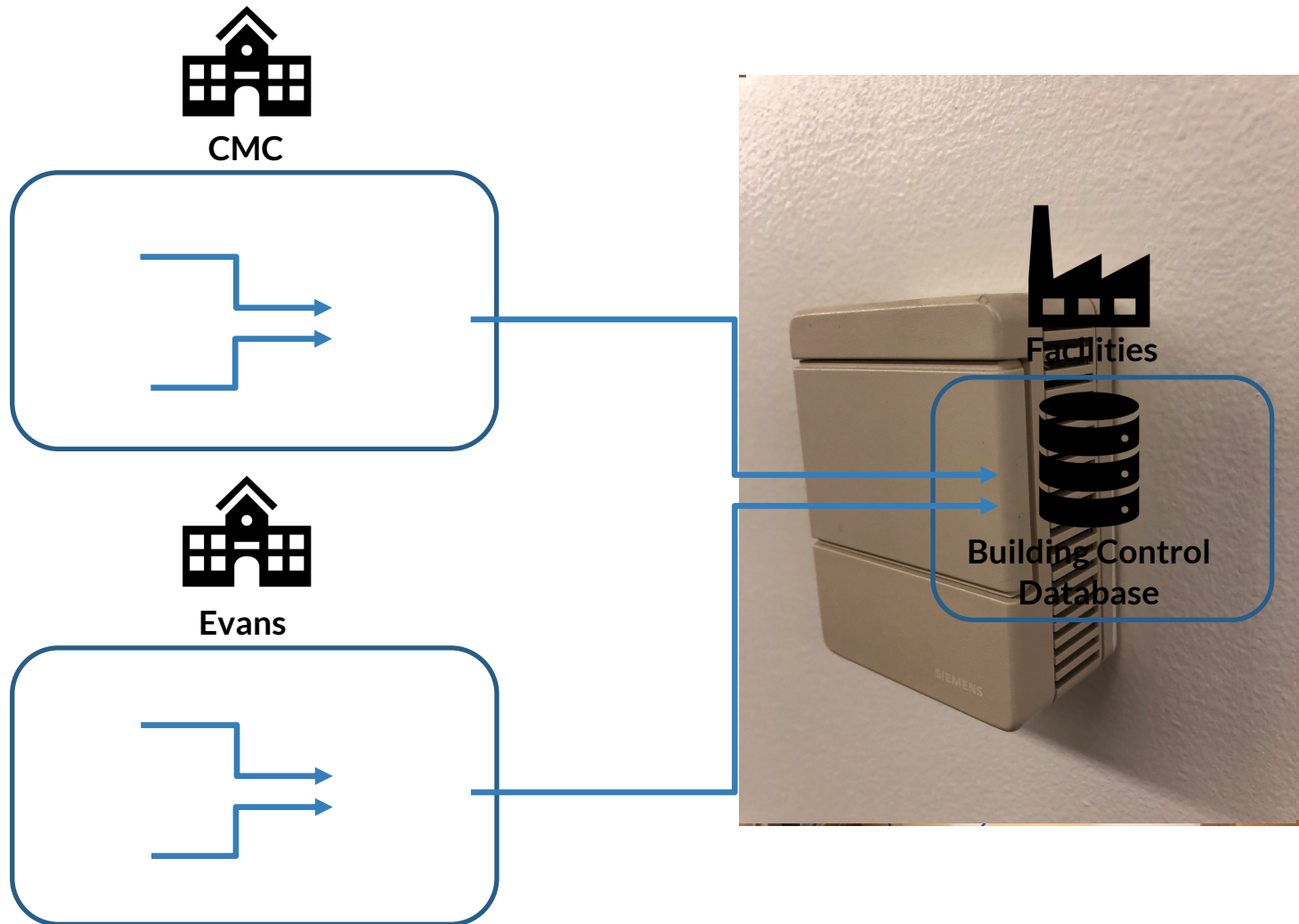

lucid[®]



Identified Needs

- ▷ Access to granular point data
- ▷ Three main use cases for point data analysis:
 - Optimization
 - Anomaly detection
 - Insights for renovation and new construction

Our Goal: Create Tools to Save Energy

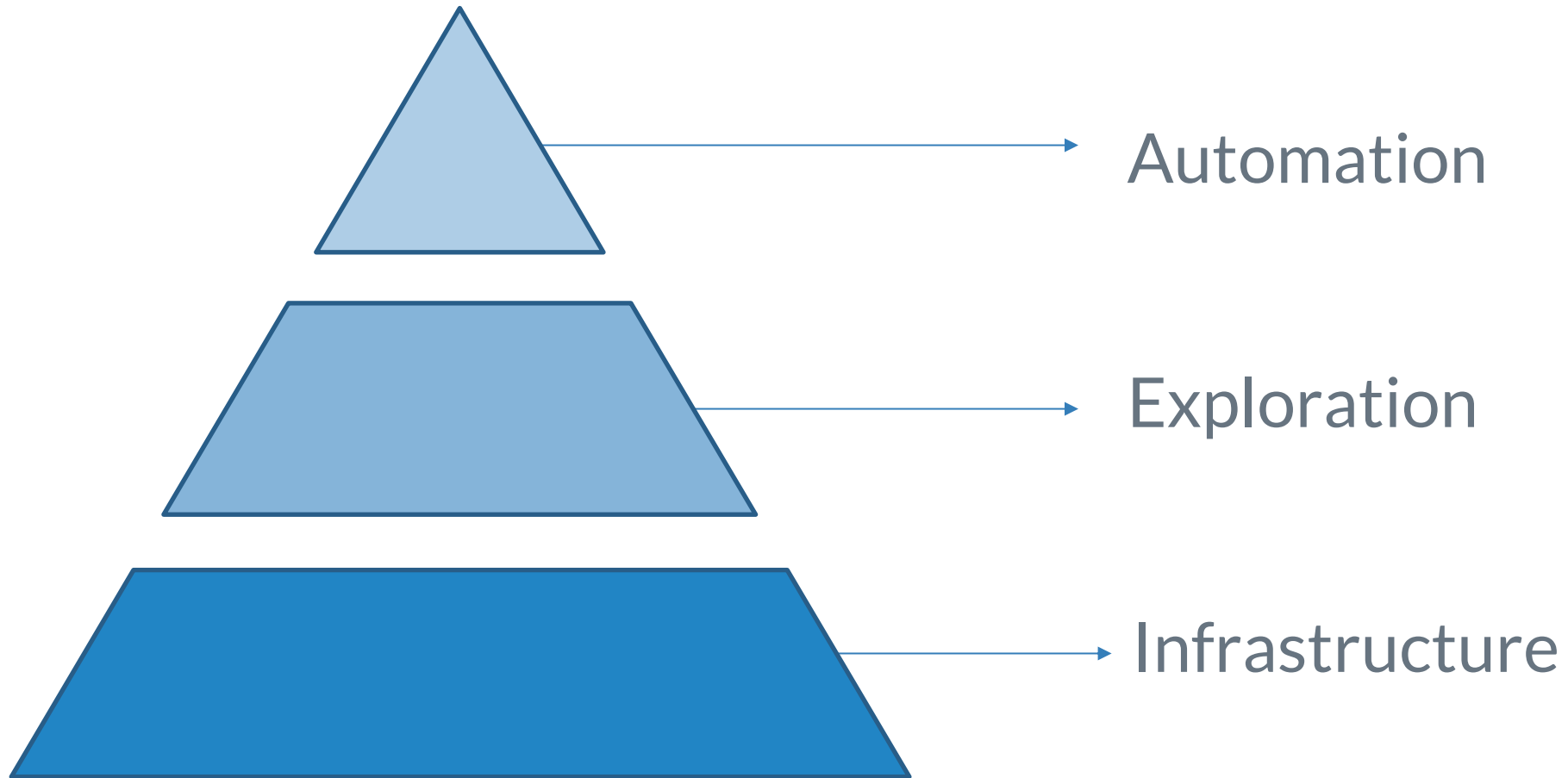

Architecture Overview

Infrastructure

Exploration

Automation

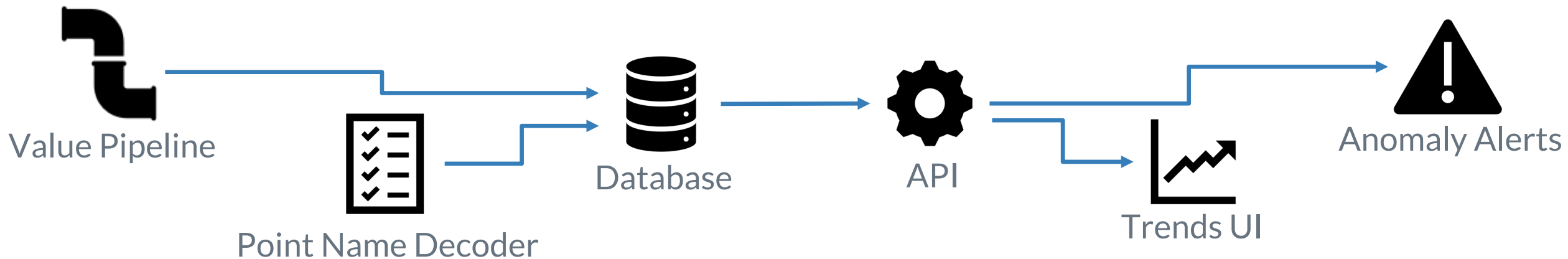

Infrastructure: Value Pipeline

Infrastructure

Exploration

Automation

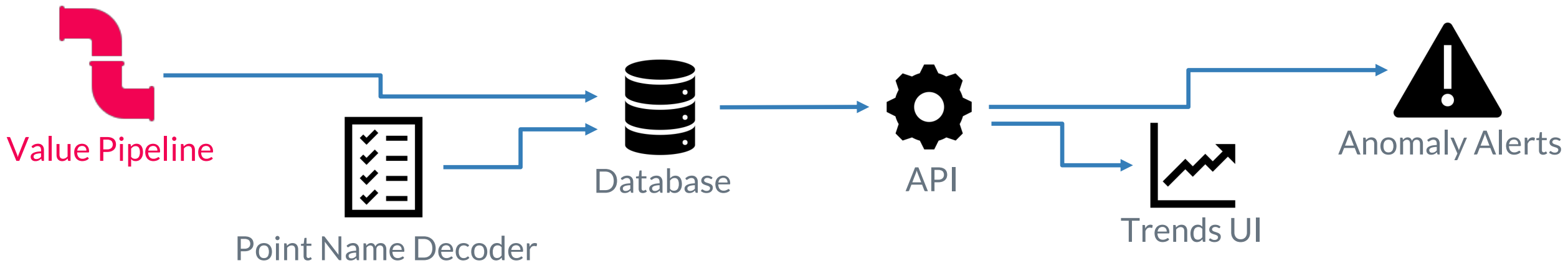

The Data — Point Definitions

▷ Static

▷ Includes Information like:

- Point Name: EV.RM003.RT
- Descriptor: G 03 ROOM TEMP
- Panel Name: EVANS.PXCM76
- Engineering unit: DEG F

53157	Point System	EV.RM003.RT		
53158	Point Name:	EV.RM003.RT		
53159	Point Type:	LAI		
53160	Classification	Building Automation		
53161	Descriptor:	G 03 ROOM TEMP		
53162	Panel Name:	PXCM76 (EVANS.PXCM76)		
53163	Point Address	FLN: 0 Drop: 22 Point: 02		
53164	Sensor Type:	MEC RTD		
53165	Slope:	1	Intercept:	-1.08913
53166	COV Limit:	1	Wire Resista	0
53167	Engineering	DEG F		
53168	Analog Repre	Float		
53169	# of decimal	2		
53170	Totalization:	None	Initial Priorit	NONE
53171	Graphic Nam	<Undefined>		
53172	Informationa	<< No Text Defined >>		
53173	Alarm Type:	Standard Alarms		
53174	Alarm Count	No		
53175	Normal ack E	Yes		
53176	Low Limit:	50	High Limit:	100
53177	Alarm Priorit	3		
53178	Print Info wit	Yes	Print Alarms	Yes

The Data — Reported Values

- ▷ Value for a point at a given time
- ▷ Each value logged every 15 minutes
 - Maximum daily potential: 9 million
 - Total values collected thus far: 14.2 million and counting!

Data Flow

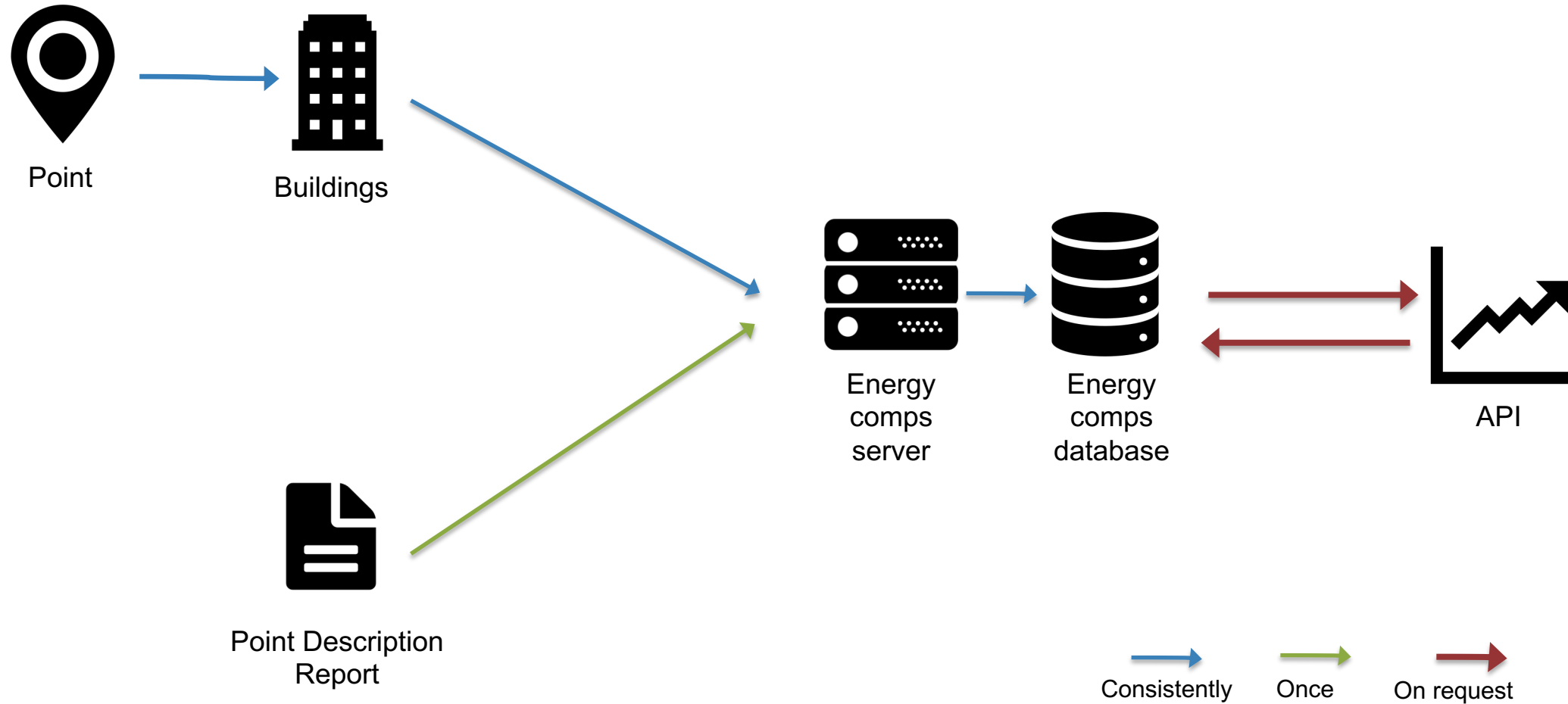

Infrastructure: Point Name Decoder

Infrastructure

Exploration

Automation

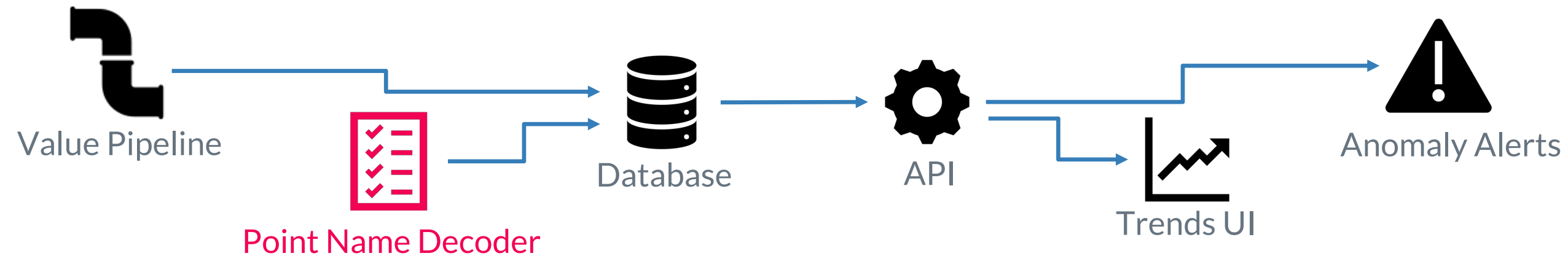

Decoding - Challenges

UNSTANDARDIZED

OUTDATED

UNDOCUMENTED

Decoding Challenge — Unstandardized

- ▷ Various naming conventions in the energy industry
- ▷ Carleton hasn't reconciled the data over time

- EV.RM102.RT
- BO.1.RM149: CTL TEMP

- Evans Room 102 Room Temperature
- Boliou First Floor Room 149 Control Temperature

Decoding Challenge — Outdated

- ▷ Renovations, naming iterations
- ▷ Obsolete names in the system
 - B vs BO
 - ACDIN

Decoding Challenge — Undocumented

- ▷ WCC-AHU12.CLG-DAT
- ▷ SEV.AH3.RAT
- ▷ MCA1RV

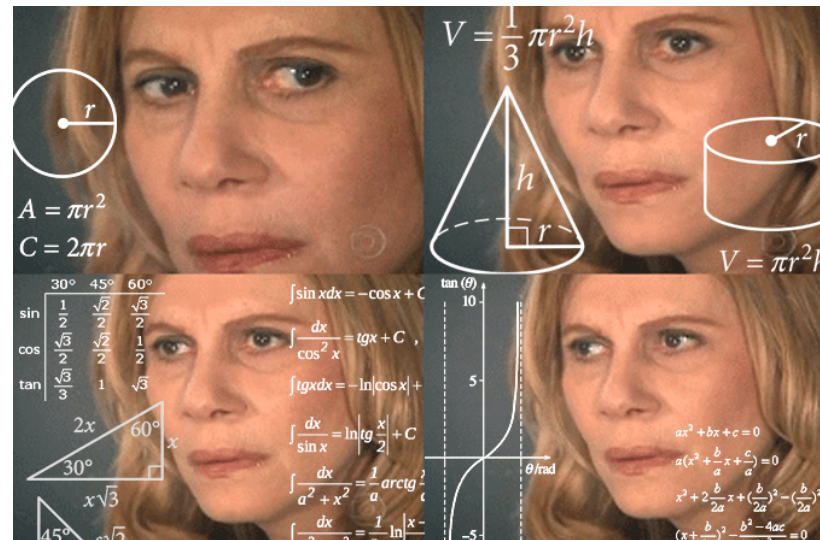
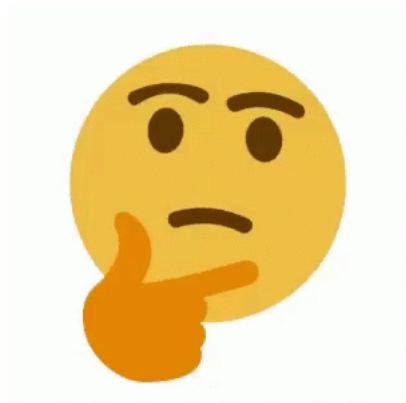

Decoding



“Decoding is the biggest challenge that’s stopping the energy industry from modernizing.”

“Microsoft spent 2 years decoding the point names on their campus.”

Decoding — Process for Determining Meaning

- ▷ Collected many mappings between device acronyms and device names
- ▷ Master decoder class + individual building decoders
- ▷ Built robust decoding infrastructure

Infrastructure: Database

Infrastructure

Exploration

Automation

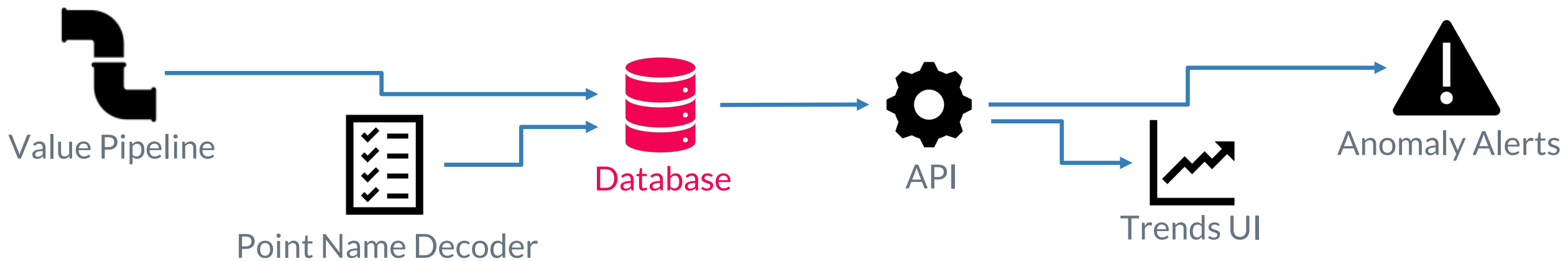

Database Design

- ▷ Store the information generated by decoders
- ▷ Be searchable
- ▷ Expressive structure for essential data
- ▷ Flexible & Extensible for the future

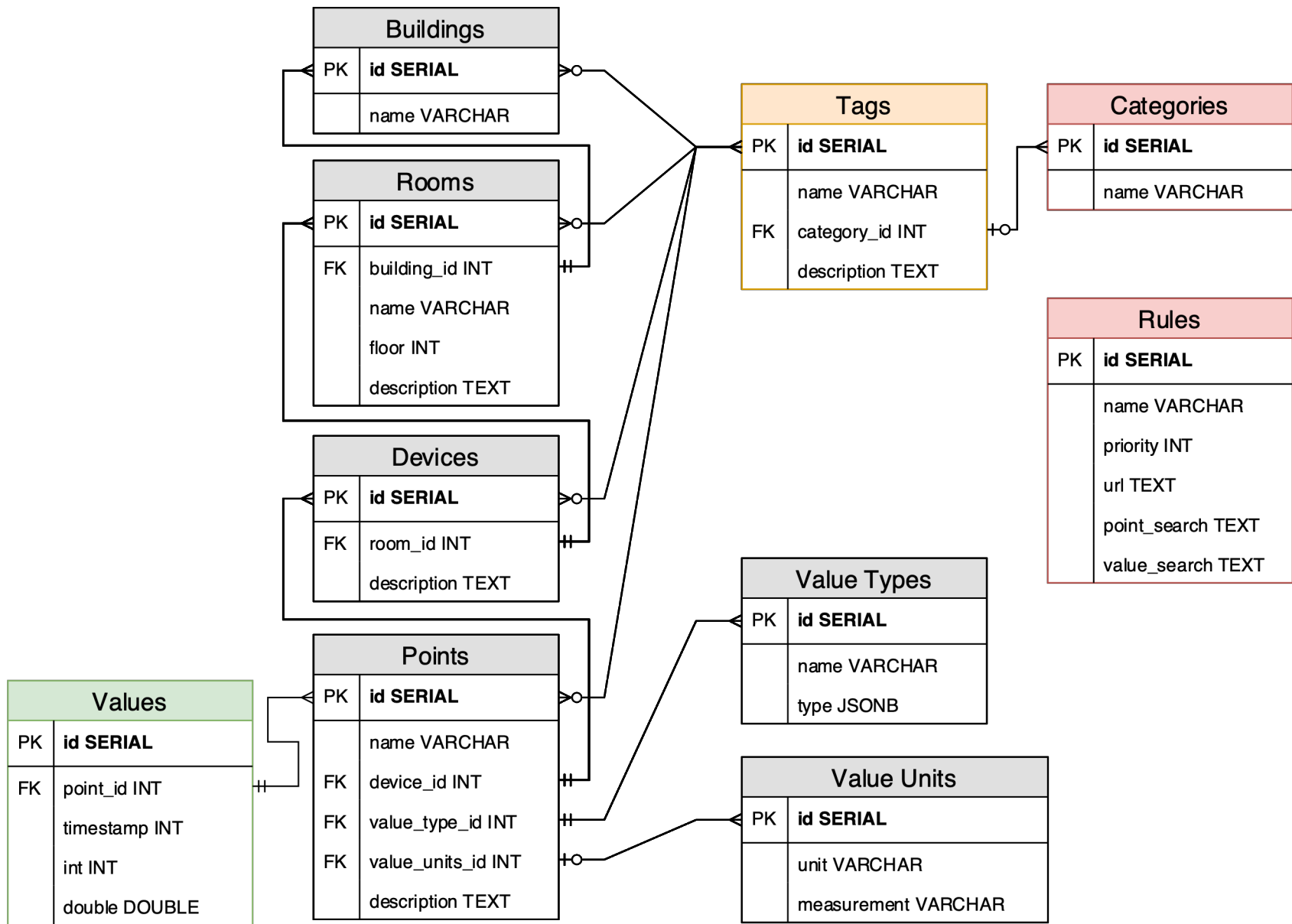

Infrastructure: API

Infrastructure

Exploration

Automation

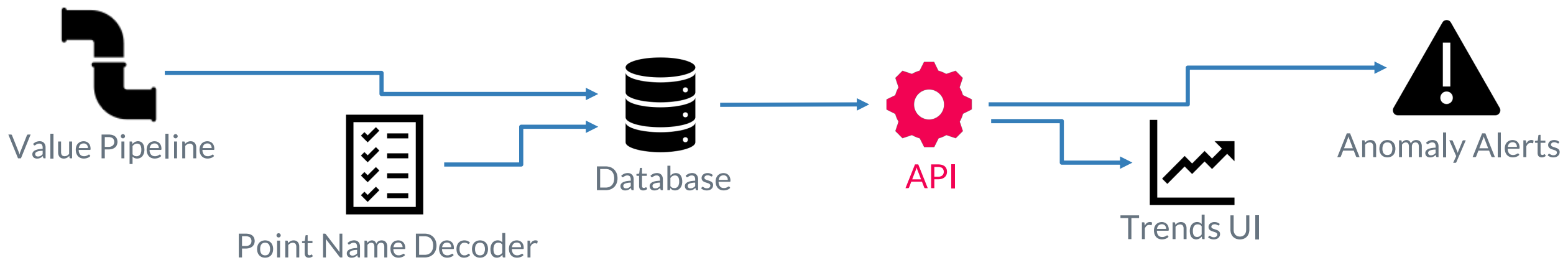

API

- ▷ Standard, controllable conduit for access to the database
- ▷ Tailor made interface
 - Does some of the work for the client application
 - Details of database design are hidden
- ▷ Problem: How to discover & specify Points to graph/analyze?

API — Standard Approach

- ▷ Points which measure Airflow

`/points?measurement="airflow"`

- ▷ Points in Leighton 213

`/room/846/points`

- ▷ Points tagged 'Room Temperature'

`/tag/12/points`

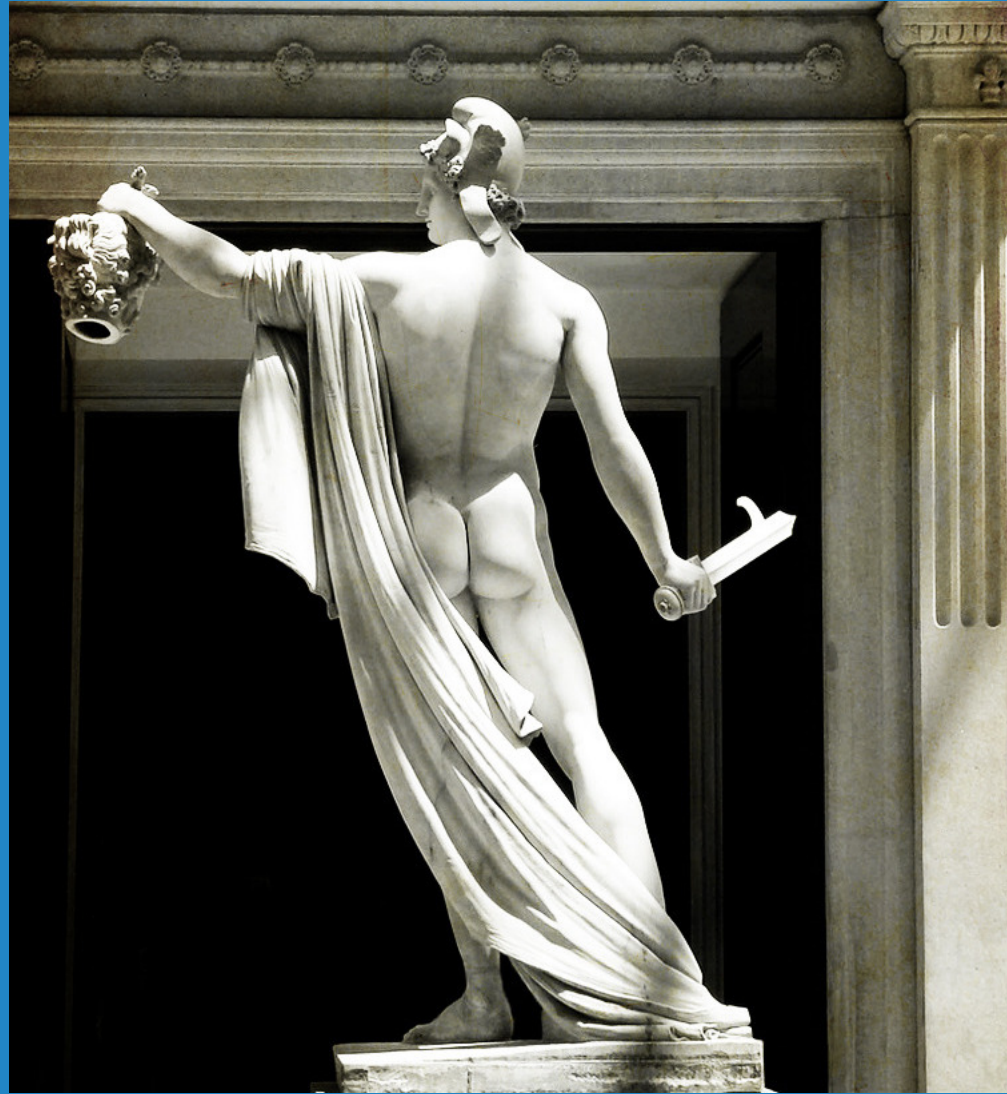







API — Standard Approach





- ▷ Not good enough!
- ▷ Too many items
- ▷ Want to filter on multiple axes

API — Standard Approach

- ▷ Room Temps and Set Points on the 3rd floor of Davis and Burton
- ▷ All classrooms in Olin except for the two lecture halls 141 and 149
- ▷ The room temperatures in all residence hall doubles with windows facing West

API — Search Engine

( Burton or  Davis) and -3 and ( Room Temp or  Set Point)
▶ Room Temps and Set Points on the 3rd floor of
Davis and Burton
(@9 or @12) and :floor = 3 and (#8 or #7)

▶ All classrooms in  Olin and  Classroom and not ( 141 or  149)
halls 141 and 149
@22 and #42 and not (\$3286 or \$3292)

▶  Room Temp and  Residence and  2-Occupant and  Faces West
doubles with windows facing West
#8 and #38 and #246 and #801

Search Engine — Technical Details

- ▷ Several Regular Expressions
- ▷ Each token individually converted to SQL WHERE clause elements
- ▷ All logic and parsing are passed through to the SQL query

Search Engine — Example

@2 and :floor = 3 and :measurement 'temperature'

```
SELECT DISTINCT points.point_id
FROM points
  LEFT JOIN devices ON points.device_id = devices.device_id
  LEFT JOIN rooms ON devices.room_id = rooms.room_id
  LEFT JOIN buildings ON rooms.building_id = buildings.building_id
  LEFT JOIN value_units ON points.value_unit_id = value_units.value_unit_id
  LEFT JOIN points_tags ON points.point_id = points_tags.point_id
  LEFT JOIN devices_tags ON devices.device_id = devices_tags.device_id
  LEFT JOIN rooms_tags ON rooms.room_id = rooms_tags.room_id
  LEFT JOIN buildings_tags ON buildings.building_id = buildings_tags.building_id

WHERE buildings.building_id = 2
  AND rooms.floor = 3
  AND value_units.measurement = 'temperature'
;
```

```
339, 345, 1784, 1657, 1118, 396, 1656, 67, 450, 1806, 1034, 2291, 2109, 1970, 485,
694, 1800, 1902, 2271, 2127, 742, 623, 1291, 792, 589, 2121, 1246, 880, 1344, 779,
252, 363, 238, 2235, 2370, 1965, 1052, 85, 1559, 1900, 1187, 349, 1765, 397, 374
```

Search Engine - Example

```
SELECT points.point_id,
       points.name           AS point_name,
       devices.device_id,   AS device_name,
       devices.name         AS room_name,
       rooms.room_id,
       rooms.name           AS building_name,
       buildings.building_id,
       buildings.name
     (SELECT row_to_json(a)
      FROM (SELECT value_type_id, type
            FROM value_types
            WHERE value_types.value_type_id = points.value_type_id
            ) a)           AS value_type,
     (SELECT row_to_json(a)
      FROM (SELECT value_unit_id, measurement, unit
            FROM value_units
            WHERE value_units.value_unit_id = points.value_unit_id
            ) a)           AS value_unit,
     (SELECT ARRAY(SELECT name
                   FROM tags
                   INNER JOIN points_tags ON tags.tag_id = points_tags.tag_id
                   WHERE points_tags.point_id = points.point_id
                   UNION
                   SELECT
```

Exploration: Trends UI

Infrastructure

Exploration

Automation

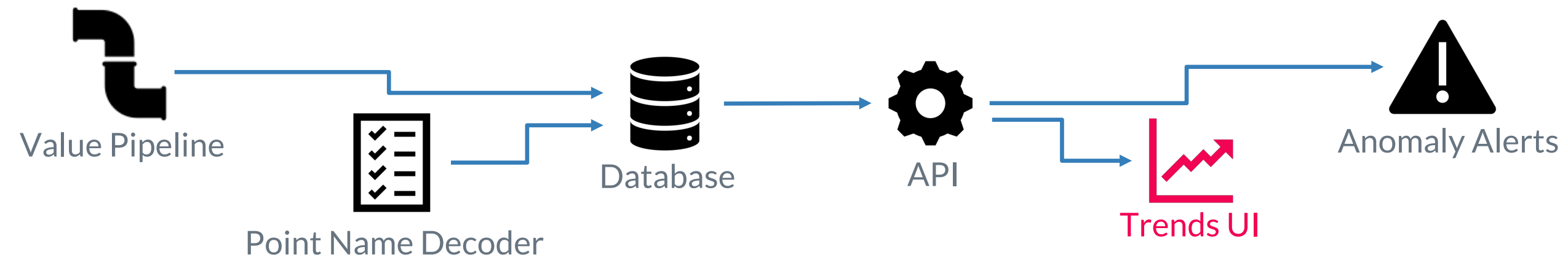

Value of a Trend UI

- ▷ Aids in understanding of buildings
- ▷ Potential to help facilities save money
- ▷ Insights for renovation or new construction

Evans Renovations



Current Limitations

1. Point Selection
2. Plot

EV.RM102.RT

EV.RM105.RT

EV.RM113.RT

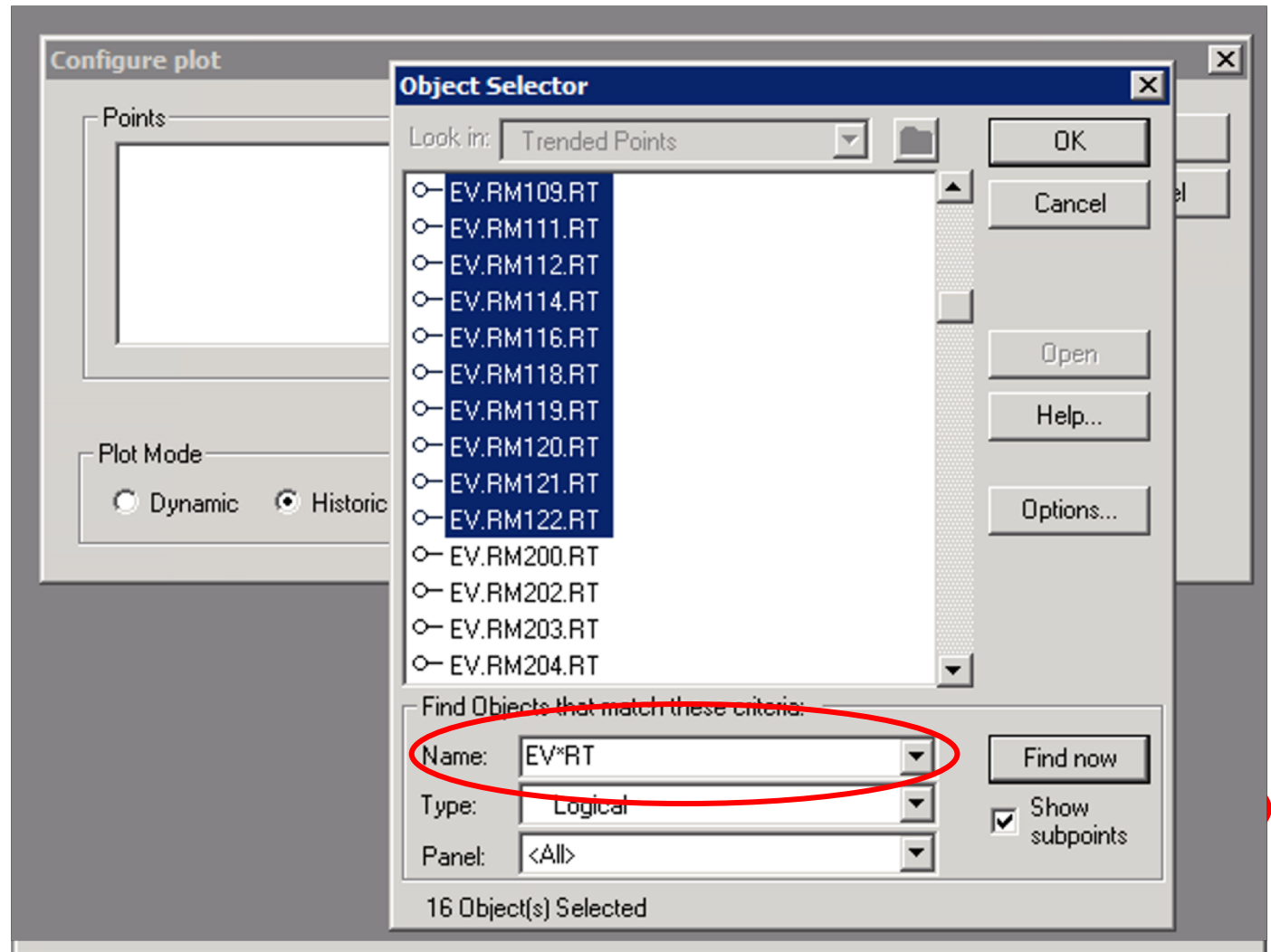

Search UI - Selecting Points

- ▷ Expose users to power of search engine
- ▷ Flexible search
- ▷ Guided exploration

- Trends
- Anomalies
- Points
- Rules

Trends

Point Selector

Building	Floor	Room	Point	Tag	Type
All Buildings	All Floors	All Rooms	All Points	All Tags	Numeric
Boliou	-1	003	BO.1.COMMONM:AIR VOLUM	Academic	Boolean
Evans	0	014	BO.1.COMMONM:AUX TEMP	Damper Command	Integer
UnID'd Building	1	016	BO.1.COMMONM:CLG FLOW	Room Temperature	Float
	2	020	BO.1.COMMONM:CLG FLOW	Residential	BACNET EVENT ENROL
	3	021	BO.1.COMMONM:CLG LOOP	Room Temperature Set Point	BACNET LENUM
	4	022	BO.1.COMMONM:CTL FLOW	Radiation Valve	BLEED_HOLD
	null	025	BO.1.COMMONM:CTL FLOW	Night Override	CHLR45
		030	BO.1.COMMONM:CTL STPT	Night Cooling Setpoint	CHLR_SEQ

3/03 12:00 AM - 3/07 12:00 AM
Graph

How to display non-numeric data?

Trends UI – Heatmap

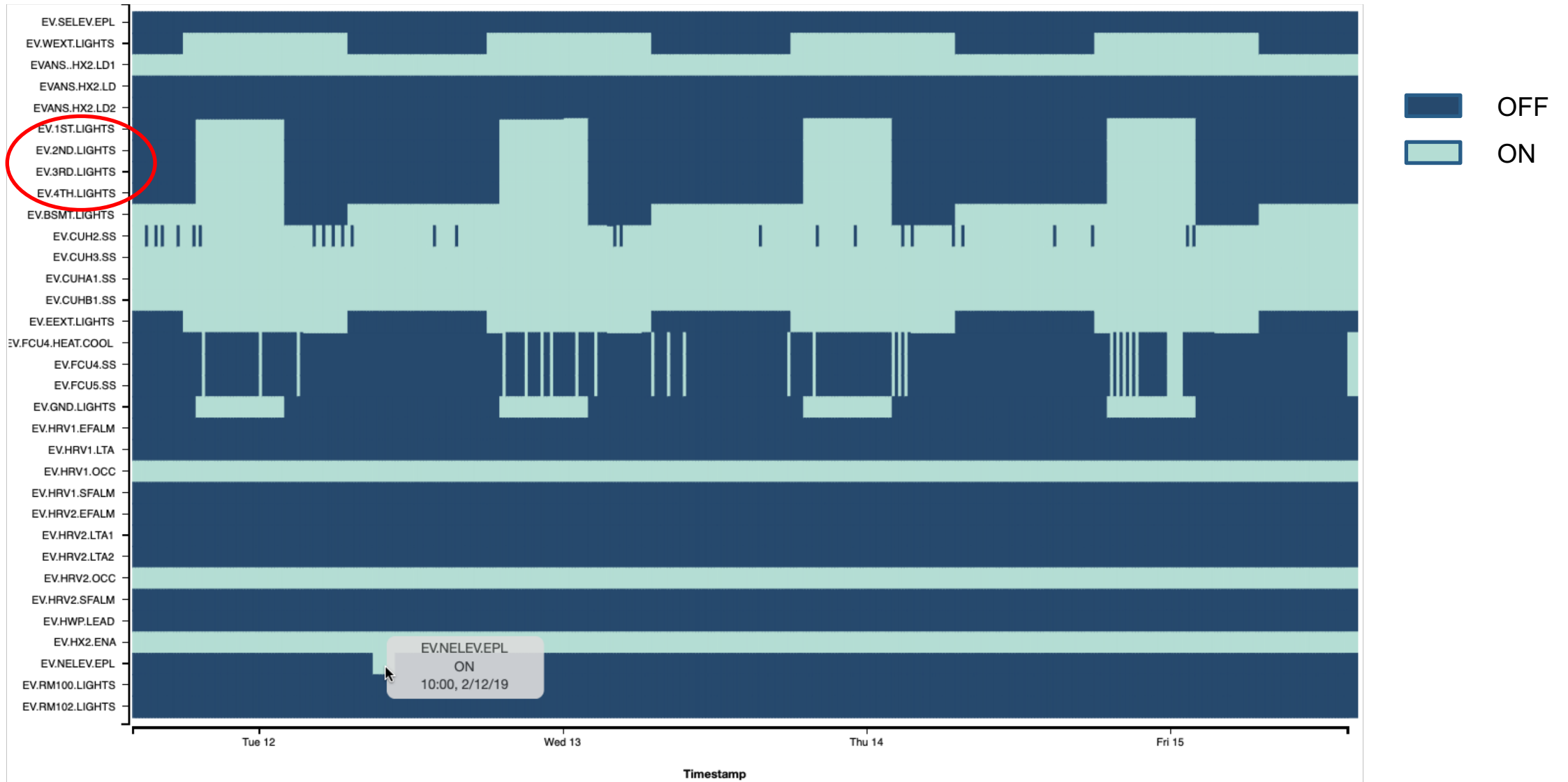

Automation: Anomaly Alerts

Infrastructure

Exploration

Automation

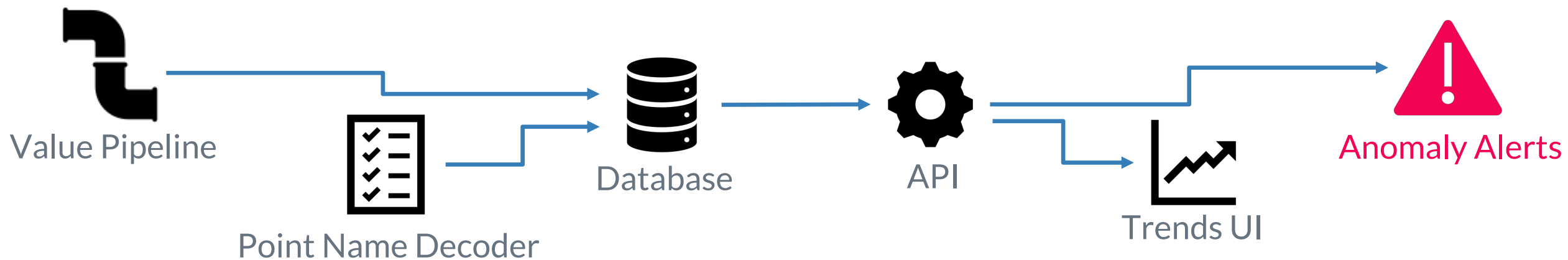

Value of an Anomaly Alert System

- ▷ Most energy loss comes from the same 10 problems
- ▷ Every year a window is left open during winter break
 - Wastes energy and money
 - Freezes the pipe, causes it to burst, and water gets all over the room

Implementing an Alert System

1. Determine what is anomalous
 - Visualize
2. Save these restrictions
 - Add alert rules
3. Notify facilities when something is flagged anomalous
 - Send an email

Visualizing Anomalies



1. Search for anomalies
2. See anomalous values in context
3. Hover for more information

Adding Alert Rules

1. Adding rules from the dashboard
2. Rule management

Point Selector

Building	Floor	Room	Point	Tag	Type
All Buildings	All Floors	All Rooms	All Points	All Tags	Numeric
Boliou	-1	003	BO.1.COMMONM:AIR VOLUME	Academic	Boolean
Evans	0	014	BO.1.COMMONM:AUX TEMP	Damper Command	Integer
UniD'd Building	1	016	D.1.COMMONM:CLG FLOW M	Room Temperature	Float
	2	020	D.1.COMMONM:CLG FLOW M	Residential	BACNET EVENT ENROLLM
	3	021	D.1.COMMONM:CLG LOOPOU	Room Temperature Set Point	BACNET LENUM
	4	022	D.1.COMMONM:CTL FLOW M	Radiation Valve	BLEED_HOLD
	null	025	D.1.COMMONM:CTL FLOW M	Night Override	CHLR45

~<62 2/27 12:00 AM - 2/28 12:00 AM Graph Create Alert Rule

Point Value

Flagged Points



EV.RM307.RT





points found

on.cad/
g%5D...

Email Alerts

Point Selector

Anomalies detected on 2019-03-06 Inbox x  

 **energycomps2019@gmail.com** 7:55 PM (0 minutes ago)   

 energycomps2019 2 Anomalies detected on **2019-02-28** The rules broken yesterday, th...

The rules broken yesterday, the number of values that flagged that rule, and the link to view more are as follows.

Rule Name	Number of Anomalous Values	Link to Dashboard
This rule rules!!!	96	view more
Set Point Rule	849	view more
Room Temperature Rule	148	view more
Evans 3rd Floor Rad Valves	20	view more

Wed 27 03 AM 06 AM 09 AM 12 PM 03 PM 06 PM 09 PM Thu 28

1. Catch problems quickly
2. Avoid alert fatigue

Demo time!

What's next

- ▷ We have built the highway! But we only have two cars 😞
 - Decode other buildings
- ▷ Develop dashboard
 - Usability
 - More features
- ▷ Automated data mining analysis
 - Machine learning
 - Clustering
- ▷ Further interview facilities staff
 - Better understand their knowledge and needs

Thank You

- ▷ Jeff  Ondich
- ▷ Martha Larson
- ▷ Eric Alexander
- ▷ Mike Tie
- ▷ Iris Jastram
- ▷ Michael Davis
- ▷ Last Year's group
 - Jon Bisila
 - Kiya Govek
 - Jack Lightbody
 - Zephyr Lucas
 - Dustin Michels
 - Carolyn Ryan

- Trends
- Anomalies**
- Points
- Rules

Anomalies

Point Selector

Building	Floor	Room	Point	Tag
All Buildings	All Floors	All Rooms	All Points	All Tags
Bollou	-1	100	EV.RM100.LIGHTS	Academic
Evans	0	102	EV.RM102.LIGHTS	Damper Command
UnID'd Building	1	106	EV.RM102.RT	Room Temperature
	2	107	EV.RM102.SP	Residential
	3	108	EV.RM102.V	Room Temperature Set Point
	4	109	EV.RM102VSP	Radiation Valve
	null	111	EV.RM106.RT	Night Override

<<60 or >>72

2/25 12:00 AM - 2/28 12:00 AM

Graph

Create Alert Rule

14 points found

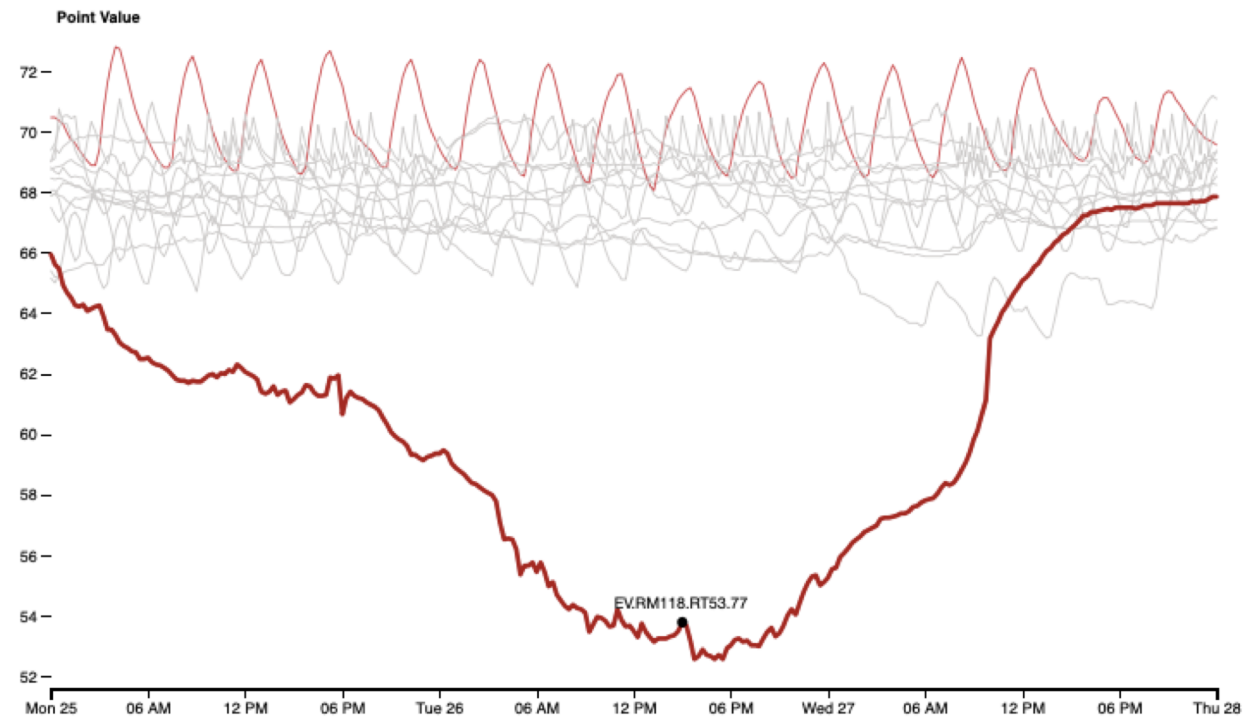

Flagged Points

- EV.RM118.RT
- EV.RM119.RT

Thanks!
Any questions?